

Electric winch

50001b

60001b

80001b/85001b

90001b/95001b

100001b/120001b

125001b/130001

150001b/160001b

165001b/170001b

200001b

Installation and operator's manual

SAFETY PRECAUTIONS

Warning! Observe safety precautions for personal safety and the safety of others. Improper equipment operation may cause personal injury and equipment damage.

Read the following carefully before attempting to operate your winch and keep the instructions for future reference.

1. Dress properly:

- Don't wear loose clothing or jewellery. They can be caught in moving parts.
- Wear leather gloves when handling winch cable. Do not handle cable with bare hands as broken wires can cause injuries.
- Non-skid footwear is recommended.

2. Keep a safe distance:

- Ensure that all persons stand well clear of winch cable and load during winch operation, 1.5 times the cable length recommended. If a cable pulls loose or breaks under load, it can lash back and cause serious personal injury or death.
- Don't step over the cable.
- All visitors and onlookers should be kept away from the work area.
- Keep proper footing and balance at all times.

3. Don't abuse the cord:

- Never carry your winch by the cord or yank it to disconnect it from the receptacle.
- Keep cord from heat, oil and sharp edges.

4. Don't overwork the winch:

- If the motor becomes uncomfortably hot to touch, stop and let it cool for a few minutes.
- Don't maintain power to the winch if the motor stalls.
- Don't exceed maximum line pull ratings shown in tables. Shock loads must not exceed these ratings.

5. Avoid unintentional starting:

- Winch clutch should be disengaged when not in use and fully engaged when in use.

6. Check damaged parts:

- Before using, you should check your winch carefully. Any part that is damaged should

Vehicle recovery electric winch

be properly repaired or replaced by an authorized service centre.

7. Repair your winch:

-When repairing, use only identical replacement parts or it may cause considerable danger for the user.

8. Re-spool the cabl

-Leather gloves must be worn while re-spooling .To re-spool correctly, it is necessary t keep a slight load on the cable .Hold the cable with one hand and the remote control switch with the other. Start as far back and in the centre as you can .Walk up keeping load on the cable as the winch is powered in.

-Do not allow the cable to slop through your hand and do not approach the winch too closely.

-Turn off the winch and repeat the procedure until all the cable except 1m is in.

-Disconnect the remote control switch and finish spooling in cable by rotating the drum by hand with clutch disengaged.

-On hidden winches, spool in cable under power but keep hands clear.

WINCH OPERATION WARNINGS

Read the following carefully before attempting to operate your winch and keep the instructions for future reference.

1. The uneven spooling of cable, while pulling a load, is not a problem, unless there is a cable pile up on one end of the drum .If this happens reverse the winch to relieve the load and move your anchor point further to the centre of the vehicle. After the job is done, you can unspool and rewind for a neat lay of the cable.

2. Store the remote control switch inside your vehicle where it will not become damaged, inspect it before you plug it in.

3. When ready to begin spooling in, plug in remote control switch with clutch disengaged, do not engage clutch with motor running.

4. Never connect the hook back to the cable, this causes cable damage. Always use a sling or chain of suitable strength.

5. Observe your winch while winching, if possible while standing at a safe distance. Stop the winching process every meter or so to assure the cable is not pulling

For further information, please contact the distributor

Vehicle recovery electric winch

up in one corner. Jamming the cable can break your winch.

6. Do not attach tow hook to winch mounting plate , they must be attached to vehicle frame.

7. The use of a snatch block will aid recovery operations by providing a doubling of the winch capacity and a halving of the winching speed, and the means to maintain a direct line pull to the centre of the rollers .When double loading during stationary winching, the winch hook should be attached to the chassis of the vehicle.

8. Ensure rated "D" or bow shackles are used in conjunction with an approved tree trunk protector to provide a safe anchor point.

9. When extending winch cable, ensure that at least five wraps of cable remain on drum at all times. Failure to do this could result in the cable parting from the drum under load .Serious personal injury or property damage may result.

10. All winches are provided with a red cable marking to identify that 5 cable wraps remain on the winch drum when this mark appears at the rollers. No recovery should be attempted beyond this marking.

11. Since the greatest pulling power is achieved on the innermost layer of your winch , it is desirable to pull off as much line as you can for heavy pulls (you must leave at least 5 wraps minimum on the drum-red cable).If this is not practical use a snatch block and double line arrangement.

12. Draping a heavy blanket or similar object over the extended winch cable is recommended as it will dampen any back lash should a failure occur.

13. Neat, tight spooling avoids cable binding, which is caused when a load is applied and the cable is pinched between the others .If this happens ,alternatively power the which in and out. Do not attempt to work a bound cable under load, free by hand.

14. Apply blocks to wheels when vehicles are on an incline.

15. Battery:

-Be sure that the battery is in good condition, Avoid contact with battery acid or other contaminants.

-Always wear eye protection when working around a battery.

-Have the engine running when using the winch, to avoid flattening the battery.

For further information, please contact the distributor

Vehicle recovery electric winch

16. Winch cable:

- Be sure that the cable is in good condition and is attached properly.
- Do not use the winch if cable is frayed.
- Do not move the vehicle to pull a load.
- Do not replace the cable with a cable of lesser strength.
- The life of the cable is directly related to the use and care it receives. Following its first and subsequent uses, a cable must be wound on to the drum under a load of at least 500lbs (230kgs) or the outer wraps will draw into the inner wraps and severely damaged the cable during winching .The first winch use should be a familiarization run while in a relaxed, non-recovery situation. Spool out the cable until the red cable mark appears (about 5 wraps on the drum), then rewind the cable on the drum under a load of 500lbs(230kgs)or more . This will slightly tension and stretch the new cable and create a tight cable wrap around the drum. Failure to do so may result in cable damage and reduced cable life.
- When the cable is replaced, be sure to apply loctite, or an equal compound, to the cable clamp thread. Tighten the clamp screw properly but do not over tighten. The loctite will prevent loosening of the screw in arduous conditions. Loctite 7471 primer and 222 thread locker are recommended.

17. Do not attempt to exceed the pulling limits of this winch.

18. Do not drive your vehicle to assist the winch in any way .Vehicle movement in combination with winch operation may overload the cable, the winch itself or cause damaging shock loads.

19. Shock loads when winching are dangerous! A shock load occurs when an increase force is suddenly applied to the cable. A vehicle rolling back on a slack cable may induce a damaging shock load.

20. The winches shown in this manual are solely for vehicle and boat mounted, non-industrial applications.

21. Do not use winch in hoisting applications due to required hoist safety factors and features.

22. Do not use the winch to lift, support or otherwise transport personnel.

INSTALLATION

Mounting your winch

1. -The winch is to be mounted into a suitable steel mounting frame using the 4 point foot mounting system in either a horizontal or vertical plane.

-It' s very important that the winch be mounted on a flat surface so that the three sections (motor, cable drum and gear housing) are properly aligned.

-The fitment of winches and /or a frontal protection system may affect the triggering of SRS air bags. Check that the mounting system has been tested and approved for winch fitment in the airbag equipped vehicle.

2. Winch mounting frames and /or frontal protection systems are suggested to suit most popular vehicles. Winch frames are packaged with detailed fitting instructions.

3. Should you wish to manufacture your own mounting plate the dimensions below will assist. A steel mount plate 6mm thick is recommended. Fasteners should be steel high tensile grade 5 or better .A poorly designed mount may void warranty.

4. The winch should be secured to the mounting with 3/8 " UNC×1-1/4 " stainless steel bolts and spring washers provided.

5. The roller fairlead is to be mounted so as to guide the rope onto the drum evenly.

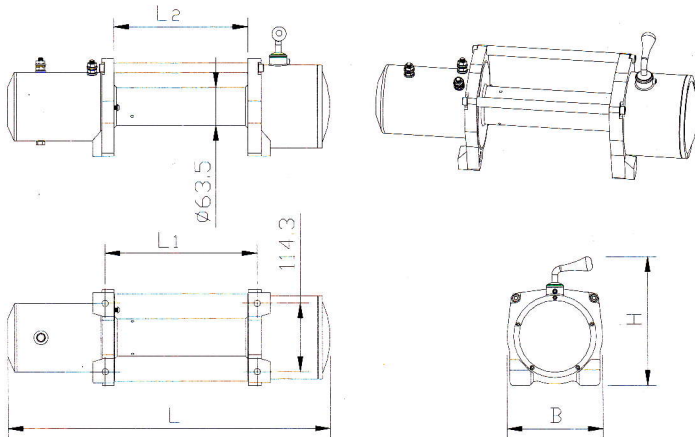

Vehicle recovery electric winch

Winch model	L	L1	L2	B	H
50001b	421	166.5	136.5	160	214
60001b	427	166.5	136.5	160	214
80001b/85001b	525	254	224	160	214
90001b/95001b	538	254	224	160	214
10001b-130001b	538	254	224	160	214

Lubrication installation

All moving parts in the winch are permanently lubricated with high temperature lithium grease at the time of assembly. Lubricate cable periodically using light penetrating oil. Inspect for broken strands and replace if necessary. If the cable becomes worn or damaged it must be replaced.

Cable installation

Unwind the new cable by rolling it along the ground, to prevent kinking. Remove old cable and observe the manner in which it is attached to the cable drum flange.

Electrical connection

For normal self-recovery work, your existing electrical system is adequate. A fully charged battery and proper connections are essential. Run the vehicle engine during winching operations to keep battery charged.

Pay close attention to proper electrical cable connection as follows:

1. Short red cable connecting to the red terminal of the motor.
2. Short black cable with yellow jacket connecting to the yellow terminal of the motor.
3. Short black cable with black jacket connecting to the black terminal of the motor.
4. Thin black cable connecting to bottom terminal of the motor.
5. Long black cable (1.8m), one terminal connecting to the bottom terminal of

For further information, please contact the distributor

Vehicle recovery electric winch

the motor ,and the other terminal negative (-) connecting to negative (-) terminal of battery.

6. Long red cable positive (+) connecting to positive (+) terminal of battery.

5000LB-20000LB Wiring diagram

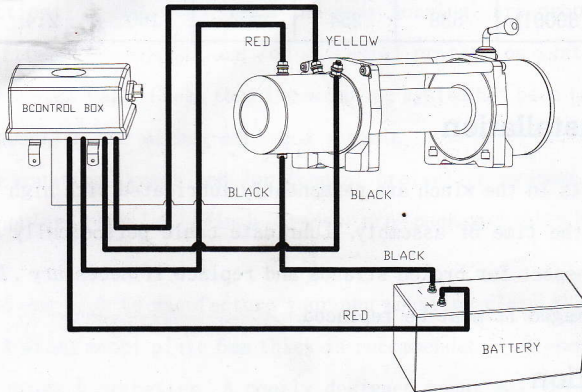

5000LB-20000LB Electric control the wiring diagram

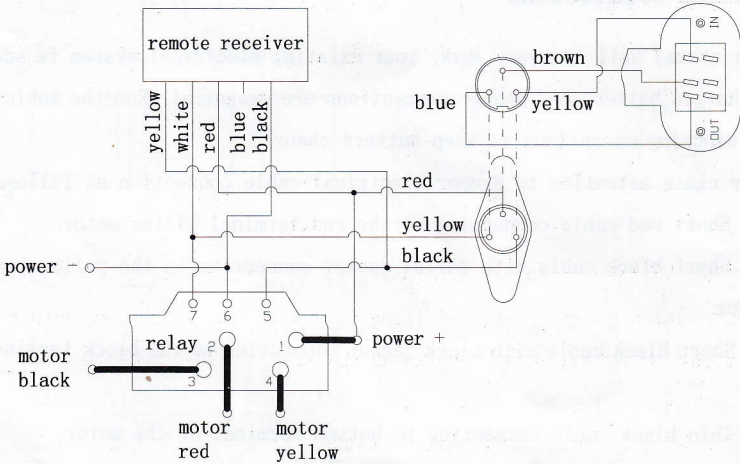

For further information, please contact the distributor

Vehicle recovery electric winch

Note

1. Your battery must be kept in good condition.
2. Be sure battery cables are not drawn taught across any surfaces .with could possibly damage them.
3. Corrosion on electrical connections will reduce performance or may cause a short.
4. Clean all connections especially in remote control switch and receptacle.
5. In salty environments use a silicone sealer to protect from corrosion.
6. Index the heads of the plate studs into the keyhole slots on the back of the winch.
7. Attach the winch /Adaptor plate assembly to your trailer hitch, by inserting the trailer hitch ball through the shaped hole in the adaptor plate.

Winch operation

Suggestion

The best way to get acquainted with how your winch operates is to make a few test runs before you actually need to use it .Plan your test in advance. Remember you can hear your winch as well as you can see it operate. Get to recognize the sound of a light steady pull. A heavy pull, and sounds caused by load jerking or shifting. Soon you will gain confidence in operating your winch and its use will become second nature to you.

Operating

1. Ensure the vehicle is secure by applying the parking brake or chocking the wheels.
2. Pull out the winch cable the desired length and connect to an anchor point. The winch clutch allows rapid uncoiling of the cable for hooking onto the load or anchor point. The shifter tab located on the gear housing of the winch operates the clutch as follows.
 - a) To disengage the clutch, move the clutch shifter tab into the "OUT" position.

For further information, please contact the distributor

Vehicle recovery electric winch

Cable may not be free spooled off the drum.

b) To engage the clutch, move the clutch shifter tab into the "IN" position. The winch is now ready for pulling.

3. Recheck all cable rigging before proceeding.

4. Plug in the winch hand control. It is recommended that the winching operation takes place from the driver's position to ensure safe operation.

5. To commence winching operation, start vehicle engine, select neutral in transmission, maintain engine speed at idle.

6. Operated the remote control switch to IN or OUT until the vehicle has been retrieved. Regularly check the winch to ensure cable is winding onto the drum evenly.

Note

1. Never winch with your vehicle in gear or in part, which would damage your vehicle's transmission.

2. Never wrap the cable around the object and hook onto the cable itself. This can cause damage to the object being pulled, and kink or fray the cable.

3. Keep hands, clothing, hair and jewellery clear of the drum area and cable when winching.

4. Never use the winch if the cable is frayed, kinked or damaged.

5. Never allow anyone to stand near the cable, or in line with the cable behind the winch while it is under power. If the cable should slip or brake, it can suddenly whip back towards the winch, causing a hazard for anyone in the area. Always stand well to the side while winding.

6. Don't leave the switch plugged in when not in use.

CHECK THE WINCH CAREFULLY AND THOROUGHLY BEFORE OPERATING!

MAINTENANCE

It is highly recommended that the winch be used regularly (once a month). Simply power the cable out 15m, free spool 5m and then power back in. This will keep all components in good working condition so that the winch can be relied on when needed. Contact your authorized outlet for technical assistance and repairs.

For further information, please contact the distributor

Vehicle recovery electric winch

TROUBLE SHOOTING

Symptom	Possible cause	Suggested remedy
Motor does not turn on	Safety switch is off	Turn safety switch to ON position
	Switch Assy not connected properly	Insert switch Assy firmly to the connector
	Loose battery cable	Tighten nuts on cable connectors
	Solenoid malfunctioning	Tap solenoid to free contact, applying 12/24 volts to coil terminal directly. Make an audible clicking when activating
	Defective switch Assy	Replace switch Assy
	Defective motor	Check for voltage at armature port with Pressed. If voltage is present, replace motor
	Water has entered motor	Drain and dry .Run in short bursts without load until completely dry.
Motor runs too hot	Long period of operation	Let winch cool down periodically
Motor runs slowly or without normal power	Battery runs down	Recharge battery by running vehicle
	Insufficient current or Voltage	Clean, tighten or replace the connector.
Motor runs bull cable drum does not turn	Clutch not engaged	Turn clutch into IN position, if that does not work, as a qualified technician to check and repair.
Motor runs in one Direction only	Defective or stuck solenoid	Tap solenoid to free contacts. Repair or replace solenoid
	Defective switch Assy	Replace switch Assy

For further information, please contact the distributor

Vehicle recovery electric winch

5000lb features and specification

Single line rated pull	5000lb (2268kg)
Motor	3.8hp/2.8kw, series wound
Control	Remote switch
Gear train	3stage planetary
Gear reduction ratio	230.4:1
Braking	Automatic load-holding brake
Drum size	Diameter 2.5" (63.5mm) × Length 9.6' (136.5mm)
Cable	Ø6.4mm × 20m
Remote control switch	Included
Extra wireless Remote switch	Optional
Battery	Recommended: 650 CCA
Net weight	25 kg
Overall dimension (length × width × height)	421 × 160 × 214mm
Mounting bolt pattern	166.5 × 114.3mm

Pull, speed, amps

Line pull lb (kg)	Line speed ft/min (m/min)	Current A
0	22 (6.8)	70
2000 (907)	11.5 (3.5)	135
4000 (1814)	12 (3.6)	190
5000 (2268)	9.5 (2.8)	235

Line pull and rope capacity in layer

Layer	Rated line pull lb (kg)	Total rope on drum ft (m)
1	5000 (2268)	29.0 (9.0)
2	4280 (1941)	48.0 (14.6)
3	3730 (1692)	69.0 (21.0)
4	3310 (1501)	79.0 (24.0)

6000lb features and specification

Single line rated pull	6000lb (3310kg)
Motor	4.5hp/3.3kw, series wound
Control	Remote switch
Gear train	3stage planetary
Gear reduction ratio	230.4:1
Braking	Automatic load-holding brake
Drum size	Diameter 2.5" (63.5mm) × Length 9.6' (136.5mm)
Cable	Ø7.2mm × 20m
Remote control switch	Included
Extra wireless Remote switch	Optional
Battery	Recommended: 650 CCA
Net weight	25.5 kg
Overall dimension (length × width × height)	427 × 160 × 214mm
Mounting bolt pattern	166.5 × 114.3mm

Pull, speed, amps

Line pull lb (kg)	Line speed ft/min (m/min)	Current A
0	26.24 (8.0)	80
2000 (907)	13.57 (4.14)	149
4000 (1814)	10.03 (3.06)	207
6000 (2721)	8.65 (2.64)	265

Line pull and rope capacity in layer

Layer	Rated line pull lb (kg)	Total rope on drum ft (m)
1	6000 (2721)	13.0 (4.0)
2	4990 (2263)	29.0 (9.0)
3	4280 (1941)	48.0 (14.6)
4	3730 (1692)	69.0 (21.0)
5	3310 (1501)	79.0 (24.0)

For further information, please contact the distributor _____

Vehicle recovery electric winch

8000lb features and specification

Single line rated pull	8000lb(3629kg)
Motor	5.2hp/3.8kw, series wound
Control	Remote switch
Gear train	3stage planetary
Gear reduction ratio	230.4:1
Braking	Automatic load-holding brake
Drum size	Diameter 2.5" (63.5mm) × Length 9.6' (224mm)
Cable	Ø8.1×28mm
Remote control switch	Included
Extra wireless Remote switch	Optional
Battery	Recommended: 650 CCA
Net weight	35 kg
Overall dimension (length×width×height)	525×160×214mm
Mounting bolt pattern	10" × 4.5" (254×114.3mm)

Pull, speed, amps

Line pull lb(kg)	Line speed ft/min(m/min)	Current A
0	22(6.8)	80
2000(907)	15.7(4.8)	140
4000(1814)	12(3.6)	200
6000(2721)	9(2.8)	270
8000(3629)	6.5(2)	330

Line pull and rope capacity in layer

Layer	Rated line pull lb(kg)	Total rope on drum ft(m)
1	8000(3629)	19.6(6.0)
2	6540(2967)	42.6(13.0)
3	5500(2495)	72(22.0)
4	4750(2167)	79(24.0)

8500lb features and specification

Single line rated pull	8500lb(3856kg)
Motor	5.2hp/3.8kw, series wound
Control	Remote switch
Gear train	3stage planetary
Gear reduction ratio	230.4:1
Braking	Automatic load-holding brake
Drum size	Diameter 2.5" (63.5mm) × Length 9.6' (224mm)
Cable	Ø8.1×28mm
Remote control switch	Included
Extra wireless Remote switch	Optional
Battery	Recommended: 650 CCA
Net weight	35 kg
Overall dimension (length×width×height)	525×160×214mm
Mounting bolt pattern	10" × 4.5" (254×114.3mm)

Pull, speed, amps

Line pull lb(kg)	Line speed ft/min(m/min)	Current A
0	22(6.8)	80
2000(907)	15.7(4.8)	140
4000(1814)	12(3.6)	200
6000(2721)	9(2.8)	270
8500(3856)	6.2(1.9)	340

Line pull and rope capacity in layer

Layer	Rated line pull lb(kg)	Total rope on drum ft(m)
1	8500(3856)	19.6(6.0)
2	6540(2967)	42.6(13.0)
3	5500(2495)	72(22.0)
4	4750(2167)	79(24.0)

For further information, please contact the distributor

Vehicle recovery electric winch

9000lb features and specification

Single line rated pull	9000lb(4082kg)
Motor	5.5hp/4.0kw, series wound
Control	Remote switch
Gear train	3stage planetary
Gear reduction ratio	230.4:1
Braking	Automatic load-holding brake
Drum size	Diameter 2.5" (63.5mm) × Length 9.6' (224mm)
Cable	21/64" (8.3mm) × 92' (28m)
Remote control switch	Included
Extra wireless Remote switch	Optional
Battery	Recommended: 650 CCA
Net weight	35.5 kg
Overall dimension (length×width×height)	525×160×214mm
Mounting bolt pattern	10" × 4.5" (254×114.3mm)

Pull, speed, amps

Line pull lb(kg)	Line speed ft/min(m/min)	Current A
0	24(7.8)	80
2000(907)	14.4(4.4)	180
4000(1814)	10.6(3.25)	240
6000(2721)	8.5(2.6)	280
8000(3629)	7.0(2.15)	330
9000(4082)	6.5(2.0)	360

Line pull and rope capacity in layer

Layer	Rated line pull lb(kg)	Total rope on drum ft(m)
1	9000(4082)	16.2(5.0)
2	7320(3320)	39.3(12.0)
3	5500(2495)	68.9(21.0)
4	4750(2167)	91.8(28.0)

9500lb features and specification

Single line rated pull	9500lb(4309kg)
Motor	5.5hp/4.0kw, series wound
Control	Remote switch
Gear train	3stage planetary
Gear reduction ratio	230.4:1
Braking	Automatic load-holding brake
Drum size	Diameter 2.5" (63.5mm) × Length 9.6' (224mm)
Cable	21/64" (8.3mm) × 92' (28m)
Remote control switch	Included
Extra wireless Remote switch	Optional
Battery	Recommended: 650 CCA
Net weight	36 kg
Overall dimension (length×width×height)	538×160×214mm
Mounting bolt pattern	10" × 4.5" (254×114.3mm)

Pull, speed, amps

Line pull lb(kg)	Line speed ft/min(m/min)	Current A
0	24(7.8)	80
2000(907)	14.4(4.4)	180
4000(1814)	10.6(3.25)	240
6000(2721)	8.5(2.6)	280
8000(3629)	7.0(2.15)	330
9500(4309)	6.4(1.95)	350

Line pull and rope capacity in layer

Layer	Rated line pull lb(kg)	Total rope on drum ft(m)
1	9500(4309)	16.2(5.0)
2	7720(3502)	39.3(12.0)
3	6500(2948)	68.9(21.0)
4	5700(2585)	91.8(28.0)

For further information, please contact the distributor

Vehicle recovery electric winch

10000lb features and specification

Single line rated pull	10000lb(4536kg)
Motor	5.7hp/4.2kw, series wound
Control	Remote switch
Gear train	3stage planetary
Gear reduction ratio	230.4:1
Braking	Automatic load-holding brake
Drum size	Diameter 2.5" (63.5mm) × Length 9.6' (224mm)
Cable	23/64" (9.1mm) × 85' (26m)
Remote control switch	Included
Extra wireless Remote switch	Optional
Battery	Recommended: 650 CCA
Net weight	36.5 kg
Overall dimension (length×width×height)	538×160×214mm
Mounting bolt pattern	10" × 4.5" (254×114.3mm)

Pull, speed, amps

Line pull lb(kg)	Line speed ft/min(m/min)	Current A
0	21.5(6.5)	65
2000(907)	11.5(3.55)	126
4000(1814)	9.4(2.85)	175
6000(2721)	7.9(2.4)	230
8000(3629)	6.5(2.0)	280
10000(4543)	5.8(1.75)	360

Line pull and rope capacity in layer

Layer	Rated line pull lb(kg)	Total rope on drum ft(m)
1	10000(4543)	19.6(6.0)
2	8000(3629)	42.6(13.0)
3	6670(3025)	72.0(22.0)
4	5720(2595)	85.5(26.0)

12000lb features and specification

Single line rated pull	12000lb(5443kg)
Motor	6.0hp/4.5kw, series wound
Control	Remote switch
Gear train	3stage planetary
Gear reduction ratio	230.4:1
Braking	Automatic load-holding brake
Drum size	Diameter 2.5" (63.5mm) × Length 9.6' (224mm)
Cable	23/64" (9.1mm) × 85' (26m)
Remote control switch	Included
Extra wireless Remote switch	Optional
Battery	Recommended: 650 CCA
Net weight	37 kg
Overall dimension (length×width×height)	538×160×214mm
Mounting bolt pattern	10" × 4.5" (254×114.3mm)

Pull, speed, amps

Line pull lb(kg)	Line speed ft/min(m/min)	Current A
0	21.3(6.5)	65
2000(907)	11.5(3.5)	126
4000(1814)	9.4(2.85)	175
6000(2721)	7.9(2.4)	230
8000(3629)	6.5(2.0)	280
10000(4536)	5.8(1.75)	355
12000(5443)	4.4(1.35)	390

Line pull and rope capacity in layer

Layer	Rated line pull lb(kg)	Total rope on drum ft(m)
1	12000(5443)	17(4.8)
2	9210(4178)	41(12.0)
3	8030(3642)	71(21.0)
4	6894(3123)	85(26.0)

For further information, please contact the distributor

Vehicle recovery electric winch

12500lb features and specification

Single line rated pull	12500lb(5670kg)
Motor	6.0hp/4.5kw, series wound
Control	Remote switch
Gear train	3stage planetary
Gear reduction ratio	230.4:1
Braking	Automatic load-holding brake
Drum size	Diameter 2.5" (63.5mm) × Length 9.6' (224mm)
Cable	23/64" (9.1mm) × 85' (26m)
Remote control switch	Included
Extra wireless Remote switch	Optional
Battery	Recommended: 650 CCA
Net weight	37.5 kg
Overall dimension (length×width×height)	538×160×214mm
Mounting bolt pattern	10" × 4.5" (254×114.3mm)

Pull, speed, amps

Line pull lb(kg)	Line speed ft/min(m/min)	Current A
0	21.3(6.5)	65
2000(907)	11.5(3.5)	126
4000(1814)	9.4(2.85)	175
6000(2721)	7.9(2.4)	230
8000(3629)	6.5(2.0)	280
10000(4543)	5.8(1.75)	355
12500(5670)	4.26(1.3)	397

Line pull and rope capacity in layer

Layer	Rated line pull lb(kg)	Total rope on drum ft(m)
1	12500(5670)	17(4.8)
2	9210(4178)	41(12.0)
3	8030(3642)	71(21.0)
4	6894(3123)	85(26.0)

13000lb features and specification

Single line rated pull	13000lb(5897kg)
Motor	6.0hp/4.5kw, series wound
Control	Remote switch
Gear train	3stage planetary
Gear reduction ratio	230.4:1
Braking	Automatic load-holding brake
Drum size	Diameter 2.5" (63.5mm) × Length 9.6' (224mm)
Cable	3/8" (9.5mm) × 85' (26m)
Remote control switch	Included
Extra wireless Remote switch	Optional
Battery	Recommended: 650 CCA
Net weight	38 kg
Overall dimension (length×width×height)	538×160×214mm
Mounting bolt pattern	10" × 4.5" (254×114.3mm)

Pull, speed, amps

Line pull lb(kg)	Line speed ft/min(m/min)	Current A
0	21.3(6.5)	65
2000(907)	11.5(3.5)	126
4000(1814)	9.4(2.85)	175
6000(2721)	7.9(2.4)	230
8000(3629)	6.5(2.0)	280
10000(4536)	5.8(1.75)	355
13000(5670)	4.1(1.25)	415

Line pull and rope capacity in layer

Layer	Rated line pull lb(kg)	Total rope on drum ft(m)
1	13000(5897)	17(4.8)
2	10010(4541)	41(12.0)
3	8840(4010)	71(21.0)
4	7410(3361)	85(26.0)

For further information, please contact the distributor

Vehicle recovery electric winch

15000lb features and specification

Single line rated pull	15000lb(6804kg)
Motor	6.0hp/4.5kw, series wound
Control	Remote switch
Gear train	3stage planetary
Gear reduction ratio	358.4:1
Braking	Automatic load-holding brake
Drum size	Diameter 23.5" (88mm) × Length 8.7' (221.6mm)
Cable	ø11mm × 26m
Remote control switch	Included
Extra wireless Remote switch	Optional
Battery	Recommended: 650 CCA
Net weight	52 kg
Overall dimension (length × width × height)	555 × 196 × 250mm
Mounting bolt pattern	10" × 4.5" (254 × 114.3mm)

Pull, speed, amps

Line pull lb(kg)	Line speed ft/min(m/min)	Current A
0	23.9(7.28)	68
2000(907)	12.2(3.7)	100
4000(1814)	9.3(2.8)	155
6000(2721)	7.4(2.25)	185
8000(3629)	6.0(1.83)	235
10000(4543)	5.1(1.55)	275
12000(5443)	4.4(1.34)	330
15000(6804)	3.3(1.0)	435

Line pull and rope capacity in layer

Layer	Rated line pull lb(kg)	Total rope on drum ft(m)
1	15000(6804)	20.4(6.22)
2	13780(6250)	42.44(12.94)
3	11200(5080)	66.74(20.35)
4	9390(4259)	85.28(26.0)

16000lb features and specification

Single line rated pull	16000lb(7258kg)
Motor	6.0hp/4.5kw, series wound
Control	Remote switch
Gear train	3stage planetary
Gear reduction ratio	358.4:1
Braking	Automatic load-holding brake
Drum size	Diameter 23.5" (88mm) × Length 8.7' (221.6mm)
Cable	ø11mm × 26m
Remote control switch	Included
Extra wireless Remote switch	Optional
Battery	Recommended: 650 CCA
Net weight	52.5 kg
Overall dimension (length × width × height)	555 × 196 × 250mm
Mounting bolt pattern	10" × 4.5" (254 × 114.3mm)

Pull, speed, amps

Line pull lb(kg)	Line speed ft/min(m/min)	Current A
0	23.9(7.28)	68
2000(907)	12.2(3.7)	100
4000(1814)	9.3(2.8)	155
6000(2721)	7.4(2.25)	185
8000(3629)	6.0(1.83)	235
10000(4543)	5.1(1.55)	275
12000(5443)	4.4(1.34)	330
15000(6804)	3.3(1.0)	435
16000(7258)	3.12(0.95)	490

Line pull and rope capacity in layer

Layer	Rated line pull lb(kg)	Total rope on drum ft(m)
1	16000(7258)	20.4(6.22)
2	14606(6625)	42.44(12.94)
3	11872(5385)	66.74(20.35)
4	9953(4514)	85.28(26.0)

For further information, please contact the distributor

Vehicle recovery electric winch

16500lb features and specification

Single line rated pull	16500lb(7484kg)
Motor	6.0hp/4.5kw, series wound
Control	Remote switch
Gear train	3stage planetary
Gear reduction ratio	358.4:1
Braking	Automatic load-holding brake
Drum size	Diameter 23.5" (88mm) × Length 8.7' (221.6mm)
Cable	ø11.5mm × 26m
Remote control switch	Included
Extra wireless Remote switch	Optional
Battery	Recommended: 650 CCA
Net weight	53 kg
Overall dimension (length×width×height)	555×196×250mm
Mounting bolt pattern	10" × 4.5" (254×114.3mm)

Pull, speed, amps

Line pull lb (kg)	Line speed ft/min (m/min)	Current A
0	23.9 (7.28)	68
2000 (907)	12.2 (3.7)	100
4000 (1814)	9.3 (2.8)	155
6000 (2721)	7.4 (2.25)	185
8000 (3629)	6.0 (1.83)	235
10000 (4543)	5.1 (1.55)	275
12000 (5443)	4.4 (1.34)	330
15000 (6804)	3.3 (1.0)	435
16500 (7484)	3.02 (0.92)	510

Line pull and rope capacity in layer

Layer	Rated line pull lb (kg)	Total rope on drum ft (m)
1	16500 (7484)	20.4 (6.22)
2	14606 (6625)	42.44 (12.94)
3	11872 (5385)	66.74 (20.35)
4	9953 (4514)	85.28 (26.0)

17000lb features and specification

Single line rated pull	17000lb(7711kg)
Motor	6.0hp/4.5kw, series wound
Control	Remote switch
Gear train	3stage planetary
Gear reduction ratio	358.4:1
Braking	Automatic load-holding brake
Drum size	Diameter 23.5" (88mm) × Length 8.7' (221.6mm)
Cable	ø11.5mm × 26m
Remote control switch	Included
Extra wireless Remote switch	Optional
Battery	Recommended: 650 CCA
Net weight	53.5 kg
Overall dimension (length×width×height)	555×196×250mm
Mounting bolt pattern	10" × 4.5" (254×114.3mm)

Pull, speed, amps

Line pull lb (kg)	Line speed ft/min (m/min)	Current A
0	23.9 (7.28)	68
2000 (907)	12.2 (3.7)	100
4000 (1814)	9.3 (2.8)	155
6000 (2721)	7.4 (2.25)	185
8000 (3629)	6.0 (1.83)	235
10000 (4543)	5.1 (1.55)	275
12000 (5443)	4.4 (1.34)	330
15000 (6804)	3.3 (1.0)	435
17000 (7711)	2.95 (0.9)	520

Line pull and rope capacity in layer

Layer	Rated line pull lb (kg)	Total rope on drum ft (m)
1	17000 (7711)	20.4 (6.22)
2	15482 (7022)	42.44 (12.94)
3	12584 (5708)	66.74 (20.35)
4	10550 (4785)	85.28 (26.0)

For further information, please contact the distributor

Vehicle recovery electric winch

20000lb features and specification

Single line rated pull	20000lb(9072kg)
Motor	6.5hp/4.8kw, series wound
Control	Remote switch
Gear train	3stage planetary
Gear reduction ratio	358.4:1
Braking	Automatic load-holding brake
Drum size	Diameter 23.5" (88mm) × Length 8.7' (221.6mm)
Cable	Ø13mm×22m
Remote control switch	Included
Extra wireless Remote switch	Optional
Battery	Recommended: 650 CCA
Net weight	53 kg
Overall dimension (length×width×height)	555×220×250mm
Mounting bolt pattern	10" × 4.5" (254×114.3mm)

Pull, speed, amps

Line pull lb(kg)	Line speed ft/min(m/min)	Current A
0	23.9(7.28)	68
2000(907)	12.2(3.7)	100
4000(1814)	9.3(2.8)	155
6000(2721)	7.4(2.25)	185
8000(3629)	6.0(1.83)	235
10000(4543)	5.1(1.55)	275
12000(5443)	4.4(1.34)	330
15000(6804)	3.3(1.0)	425
17000(7484)	2.95(0.9)	495
20000(9072)	2.62(0.8)	530

Line pull and rope capacity in layer

Layer	Rated line pull lb(kg)	Total rope on drum ft(m)
1	20000(9072)	20.4(6.22)
2	15482(7022)	42.44(12.94)
3	12584(5708)	60.18(18.35)
4	10550(4785)	72.16(22.0)

5000-13000lb winch parts list

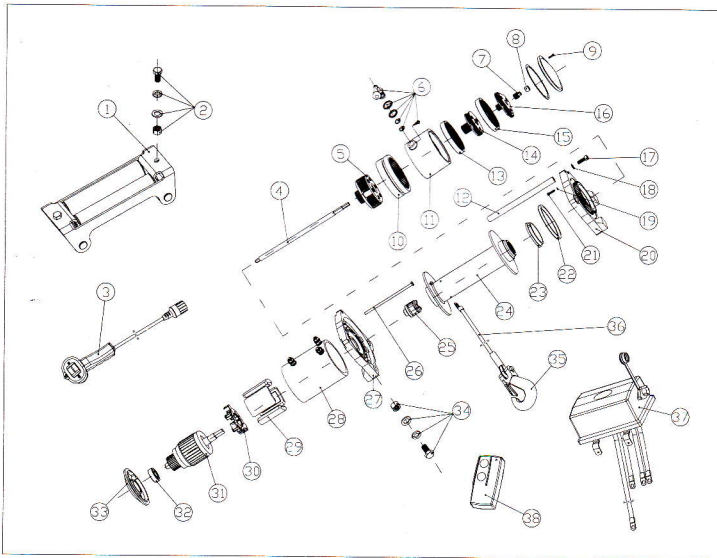

For further information, please contact the distributor

Vehicle recovery electric winch

Item No.	Description	Qty	Item No.	Description	Qty
1	Roller Fairlead	1	18	Washer 8	4
2	Mounting Bolt Assy of Roller Fairlead	2	19	Spring Washer 4	10
			20	Gear Box Bracket	1
3	Switch Assy	1	21	Link Screw M4×20	10
4	Transmission shaft	1	22	Waterproof Circle	2
5	Gear carrier Assy - output	1	23	Sliding Bearing	2
			24	Drum Assy	1
6	Clutch Handle Assy	1	25	Brake	1
7	Sun Gear -input	1	26	Mounting Bolt	2
8	Sliding Bearing	1	27	Motor Bracket	1
9	Link Screw M4×16	5	28	Motor- Box-Tube	1
10	Clutch Gear	1	29	Stator	1
11	Gear Box-Tube	1	30	Carbon Brush Assy	1
12	Tie Bar	2	31	Rotor	1
13	Intermediate Gear	1	32	Bearing 6203	2
14	Gear carrier Assy- intermediate	1	33	Motor End Cover	1
			34	Mounting Bolt Assy	4
15	Iner Gear	1	35	Hook	1
16	Gear Carrier Assy- input	1	36	Wire Rope	1
			37	Solenoid Box Assy	1
17	Link Screw M8×25	4	38	Wireless remote swirch	1

For further information, please contact the distributor